



CBC (EUROPE) Ltd.

Pocket Guide to CCTV



An installation
pocket guide
to closed circuit
television systems

computar[®]

GANZ

CONTENTS

Introduction Page 02

CCTV Basics Page 05

System Components Page 06

Applications matrix Page 16

Entry Level Systems Kits Page 18

Intermediate Level Systems Kits Page 28

Design and Build your CCTV Page 48

Application Examples Page 52

Data Protection Act Page 55

The Operational Requirement Page 56

Reference Information Page 57

Welcome to the CBC (Europe) Pocket Guide to CCTV

This is an installation guide for everyone with an interest in closed circuit television systems. It contains all the essential information that is required by those wishing to become involved with these systems, and for those who are already active, and is presented in an easy to read format.

Using the Guide

The CCTV industry and the application of components within it, is extremely diverse. With this in mind the CBC (Europe) Pocket Guide has been compiled to help the installer come to understand the basic role and the functions of all of the components and equipment used in traditional CCTV systems.

By referring to the applications matrix in the guide it becomes possible to select a CBC (Europe) entry level kit or an intermediate level kit to be used for any mainstream CCTV application. This matrix also helps the installer to appreciate the fundamentals of the selection process in terms of the parts being specified in any given kit.

In order to allow installers to select the most efficient components for any CCTV role, and to ensure full compatibility between all of the CCTV interconnected items, CBC (Europe) developed this range of kits.

These kits are for general duties and include clearly defined components. In view that they range from entry level through to intermediate level the installer can easily order a purpose designed kit system that will truly satisfy any wide ranging but time honoured monitoring application.

For those who would like to become involved at a higher scale the guide covers how to Design and Build your CCTV that enables the installer to produce a system custom designed for any CCTV activity. For these more diverse system applications additional components can easily be added to provide a wider range of functions.

Following on from the applications matrix the guide itemises the various components used in the different kits and includes installation criteria and applications hints.

The modular systems are represented in schematic form so that the installer can easily determine what additional components may be needed for the more involved CCTV scheme.

This guide also contains application examples. These are effectively installation considerations that apply to any CCTV system. The typical examples shown give prompts to help the installer to obtain the best possible results from the proposed system and to avoid any pitfalls in the installation process.

Information on the Data Protection Act and the Operational Requirement have been included as the installer should have a basic understanding of these issues and how they are applied in the CCTV industry.

A reference information section contains details of the handover and maintenance policies that are required.

This helps the installer to appreciate the requirements for the commissioning of the system, the techniques needed to present it to the client and the ongoing maintenance policies.

A glossary of terms is also provided.

Our highly trained technical department offers even greater levels of help and advice on all aspects concerning the operation of our full product range so as to provide a unique and comprehensive service.

For technical help on any of our products call 020 8732 3350/3353.

CCTV Basics: CCTV – A Self Contained System

As the term implies CCTV is a self contained system in that all of the circuits contained within it are closed and directly connected.

This is unlike 'broadcast television' where the signals are accessed by special receiving equipment that is tuned to collect signals from across the airwaves.

Although CCTV has always had a high profile role to play in the security industry it is now also being increasingly used to great effect in even more wide ranging monitoring and control applications. Therefore the true potential of CCTV is becoming understood as it expands its scope to aid both the operational surveillance practices being employed by traditional organisations and those involved with specialist surveillance.

Although every CCTV system exists as a self contained technique and can be managed and controlled in its own right it can always play an enhanced role by integrating it with other management systems and networks. From this it follows that CCTV can play a principal role in many wider networks even though it continues to retain its own individual identity.

In practice the full range of component parts used within the CCTV industry is extremely wide ranging and diverse. However by referring to this guide and by using the selection processes that it contains will enable the installer to select a kit, or the parts to form your Design and Build CCTV system, to satisfy any application. The installer will certainly also be assured that the selection of components will be fully compatible with each other and operate together to form a truly effective system.

The general availability of versatile CBC (Europe) high quality components for use within the industry presents enormous opportunities for all those personnel seeking to become involved with CCTV and for those who are already active at every level.

The Essential Devices

Although the application of CCTV and the range of available components is extremely diverse, we can say that in its most basic form any system must consist of a number of essential devices.

These devices or components must be compatible and work together in an efficient way if the CCTV is to be truly effective.

These essential devices are namely:

Camera

Lens

Cables

Recording and monitoring equipment

Illumination

In order to appreciate how CCTV systems actually operate an overview of each of these essential devices is given in relation to the products used within the CBC (Europe) systems covered by this guide. These overviews contain everything that the installer needs to know at foundation level, and reflect the fundamentals of CCTV.

By referring to these overviews the installer is able to understand why particular products have been selected for use in the CBC (Europe) entry and intermediate level system kits.

They will also enable anyone specifying Design and Build CCTV systems to appreciate the roles of some of the wider functions of these devices and the terminology that will be encountered.

Camera

The term 'camera' comes from the Latin 'camera obscura' which means 'dark room'. The principle duty of the camera is to project an image onto different targets using light and lenses but which by their very nature differ widely. There are many factors that have an effect on camera selection including the working environment and lighting levels and all of these variables need to be balanced against the requirement to resolve fine detail in the picture. **THE PICTURES WILL THEREFORE BE REFERRED TO AS STANDARD OR HIGH RESOLUTION.**

Despite the enormous range of cameras and their functions and attributes we can provide a number of fundamentals that should be understood.

Monochrome Cameras

Black and white cameras are superior to colour cameras in low lighting environments. Monochrome cameras can also be matched to infra red (IR) illumination which is lighting that is invisible to the human eye.

Colour Cameras

These are superior in identifying and tracking a target.

Colour/Mono Cameras

These are 'day' and 'night' cameras. These provide high quality colour images in normal light conditions. However when the light levels become low the camera switches from colour to black and white mode.

Dome Cameras

An assembly containing a camera within the confines of a dome. With all dome camera systems the observer does not know when they are under surveillance.

IR Colour/Mono Cameras

These are an assembly consisting of a camera and lens, plus an integral infra red (IR) light emitting diode (LED) array assembly unit. They provide around the clock optimum performance in demanding lighting conditions by switching from colour to mono in low light and triggering the IR assembly unit. The effective range of the IR illumination will be quoted in the camera data.

Lens

The lens is an optical device which is attached to the camera. It is used to gather light from the scene that is being viewed and to focus this light from the front of the lens to the electronic pick-up (imaging device) within the camera. Therefore the lens works in a similar way to the human eye, which focuses the images of the things that we see on the retina at the back of the eye.

WHEN CONSIDERING THE LENS IT IS IMPORTANT TO UNDERSTAND THE SIGNIFICANCE OF THE ANGLE OF VIEW AND THE LIGHTING.

THE ANGLE OF VIEW OR SCENE

The focal length of the lens is directly related to the angle of view or scene. Short focal lengths give a wide angle of view.

As the focal length increases the view of the camera becomes narrower. We tend to refer to a lens with a 'normal' angle of view as similar to what is seen by the human eye i.e. an angle in the order of 35°.

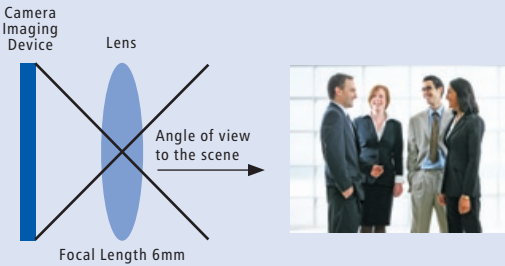

As the focal length increases the angle of view becomes narrower.

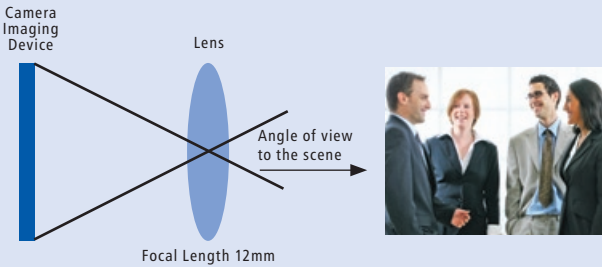

From this we can come to understand the techniques associated with the following types:

FIXED FOCUS LENS
VARI-FOCAL LENS
ZOOM LENS

Fixed Focus Lens

These have a fixed focal length and are used when the angle of view is not intended to be altered or adjusted. It is the most basic form of CCTV camera lens. These lenses are extremely cost effective and can make the quote for a system highly competitive.

Vari-focal Lens

This type of lens allows the focal length to be manually adjusted slightly during the installation. It allows for the field of view or scene to be altered to a small extent during set-up which allows a limited margin of error.

Zoom (Telephoto) Lens

Has a long focal length to produce high magnification but a narrow angle of view. The manual zoom lens offers a wide adjustment at set-up. The motorised zoom lens is used by an operator to automatically change the field of view to zoom in and out on a target.

NOTE: *All of the kits covered by this guide use either fixed focus or Vari-focal lenses depending on the specific application types. Zoom lenses are only used in purpose design CBC (Europe) pan/tilt/zoom systems with automatic control or telemetry but for the purposes of lens fundamentals should be understood.*

Remember

Pay attention to the selection of lens with particular regard to the angle of view and to the lighting at the scene at different times of day. Practical hints are given throughout the sections in this guide relating to the different kits. The artificial illumination used for the lighting at the scene should also be referred to in the system components section.

The Lighting

We know that the lens is used to gather light from the scene and to focus this light onto the electronic pick-up device within the camera. Therefore it follows that the quality of the final image will be influenced to a great extent by the natural light available to the lens at the scene, and by any artificial illumination that must be provided when natural light is not available.

To give the best image quality it is absolutely vital that the correct amount of light reaches the camera sensor via the lens. In practice this is regulated by the lens iris. Therefore we need to appreciate the fundamentals of the lens in relation to the operation of the iris.

Manual Iris Lens

These are only used where the lighting levels remain constant and are found typically in internal applications. The iris with this lens type is set at the time of installation to suit the lighting levels generally available.

Auto Iris Lens

These automatically adjust to changes in the lighting levels so are most prominent in external applications to compensate for fluctuating lighting levels.

Aspherical Lens

These have special optics and achieve better sensitivity with cameras used in low lighting installations. The aspherical lens gives increased performance when lighting conditions are poor, effectively giving a sharper, clearer image at dusk and at daybreak.

IR Corrected (Day and Night) Lens

This lens type is used for night time surveillance with infra red lighting. They provide a much more vivid picture when used at night with colour/mono cameras.

Cables

The principal cable forms used in CCTV systems are co-axial cables and Category 5 (Cat 5).

Co-axial Cable

Co-axial cable is the traditional medium for carrying the CCTV signals. It features a centre copper conductor core which is insulated and then screened by an outer shield or braid. Co-axial cable is terminated for CCTV purposes with an appropriate form of BNC connector.

The CBC (Europe) kits come complete with a 1 metre long pre-wired multi co-axial cable to form the link between the control equipment and the power supply unit (PSU). This cable is colour coded and is capable of connecting up to four individual cameras.

Cat5

Cat5 is actually a communications cabling form that has been adopted by the CCTV industry. It employs four pairs of cables that are twisted along their full length. It is these twists that give the cable pairs added protection against electrical interference being induced into the wiring. Cat5 cable is also capable of carrying the CCTV signals far greater distances than co-axial cable.



Cat5 is a form of unshielded twisted pair (UTP) cable but to more exacting requirements and with particular characteristics. For these reasons it should never be replaced by standard twisted pair, multi core or screened cable as this will have an effect on the system performance.

Cabling of Kits

All CBC (Europe) entry level and intermediate level system kits come with factory produced pre-wired cables and connectors where appropriate.

These cables can be easily connected to the appropriate converter boxes and PSU devices without any need to make up terminations at the installation site.

Supplying pre-wired cables with the kits is an added assurance to all installers that superior joints and terminations have been 'made up' in a high quality manufacturing environment.

All of the cables for use in the CBC (Europe) kit systems are supplied and identified with unique part numbers, to include the link cable between the monitor and the control and monitoring equipment.

In practice the installer need only ensure that the cables are installed as per the relevant standards for electrical wiring.

It should be noted that co-axial and Cat5 cabling can only work to their design specifications when its rules for installation are adhered to. In this respect excessive bending of the cable is to be avoided together with stretching or crushing as these will alter the cable characteristics.

Protection should be applied to cables where they could be subject to mechanical damage or difficult environmental conditions.

In the area of the control equipment attention should be given to the security of the wiring to ensure that connections can not be put under strain so that they could become detached from sockets etc.

Recording and Monitoring Equipment

The Logic of Recording and Monitoring

In order to be able to view and also record the images from a camera there is a need to have some form of control equipment. This equipment must be capable of working in conjunction with the monitor screen or screens on which the pictures are to be displayed.

We refer to such equipment as recording and monitoring equipment.

The Devices Used for Recording

All of the CBC (Europe) kits and Design and Build CCTV systems covered by this guide use a digital video recorder (DVR). This operates as the main control equipment, carries out the recording practice and transmits the images to the monitor.

DVR

The DVR is used to record and store the CCTV images digitally onto a built-in hard drive from a number of cameras. The DVR is able to control a given number of cameras and which are identified as channels. These multiple images from the cameras can then be transmitted to a single monitor screen for viewing in a number of different ways e.g. individually or on a multiscreen so that all images can be displayed simultaneously. This becomes a requirement if more than one camera is to be viewed, or recorded, and shown on a single monitor screen.

The data that is stored can be replayed locally at the DVR through a CCTV monitor or it can be connected into a PC network. The DVR can be set to store 25 pictures every second to give an image that is seen by the human eye as a moving picture with no flicker. This is known as 'real time' and gives a picture similar to that of broadcast TV. However to make a greater use of storage space the equipment can be set to a time lapse mode. By using this technique the recording hours can be changed so that less information (number of pictures) will be stored. This can be set by the installer to suit the specific application.

Remember:

The DVR takes on the role of both the switcher, multiplexer or quad used in conjunction with a time lapse VCR that will be found traditional analogue systems.

The Devices Used For Monitoring

The devices used to view the image are monitor screens and may be traditional CRT screens or new generation TFT LCD screens. Monitors for CCTV applications are similar to television receivers except that they do not have the tuning circuits. All monitors are available in different sizes to suit the application.

They may be complemented by slave monitors so that the images from the cameras may be viewed at more than one location. The monitor has two BNC connectors. One is provided to accept the signal from the camera or the recording equipment and the other is to loop through to the slave if required. The correct size of monitor depends on the number of images to be displayed at any given time, the viewing distance and the available space.

The Need For Further Control Equipment

Alongside the camera control and recording equipment there may be a need for telemetry. This is effectively a signalling system used to control functions at the camera head such as pan, tilt and zoom. There may also be such features as wash/wipe to clear the camera housing screen.

In order to carry this out signals are generated at a controller key pad or joystick which is sited close to the monitor. The signals are sent to a receiver which is located adjacent to the camera head. This provides information to the drive motors or similar components which are used to carry out the function.

Although telemetry does not actually form a part of the kits covered by this guide, they may, in practice, be connected into such systems in a supporting role in order that their images could be displayed on demand from a further network.

Illumination

The Need For Illumination

As the camera can only gather light that is reflected from the scene it follows that the quality and quantity of light is of vital importance. Therefore we need to provide illumination when natural light is not available. This is done by using either general overt lighting or Infra red (IR) covert illumination which is invisible to the human eye but the black and white monochrome camera can 'see'.

In the first instance we can overview overt illumination before looking at the considerations of covert lighting:

Overt Illumination

INCANDESCENT LIGHTING

These use a filament such as those found in a general use electric light bulb. This is heated to the extent that it produces a white glow.

GENERAL FILAMENT LIGHTING: Acceptable for internal applications

TUNGSTEN HALOGEN: Good colour rendering but uneconomic.

FLUORESCENT LIGHTING

These produce an emission of light as a result of a gas discharge.

Good colour rendering. More economic than incandescent lighting.

HIGH INTENSITY DISCHARGE (HID)

Specialist lighting for reliable and consistent use over long periods of time. Have starting circuits. Start up periods and re-strike periods mean these illuminators should only be used with CCTV over extended operating periods. Economic.

LOW PRESSURE SODIUM (SOX): The predominant source in urban street lighting. It can not discriminate colours in CCTV systems.

HIGH PRESSURE SODIUM (SON): Respectable colour rendering in CCTV systems.

METAL HALIDE (HPI): Gives good colour rendering.

HIGH PRESSURE MERCURY VAPOUR: An option to metal halide with adequate colour rendering.

LED ILLUMINATION

LED technology for both white light and infra-red illumination. This type of lighting offers low running costs and extremely long life.

Covert Illumination

Infra red (IR) is illumination that can be used with the monochrome camera. It is illumination that is designed with the camera in mind and not for the human eye.

Infra red illumination lies in a bandwidth of the electromagnetic spectrum that is not visible to the human eye. This means that we can not see infra red light however it can be 'seen' by a monochrome camera.

With IR systems the lens and angle of view are matched to the lens and area of illumination of the lamp.

All CBC (Europe) kits employ IR colour/mono cameras for external use. These assemblies contain a camera and lens plus an infra red (IR) light emitting diode (LED) assembly.

The lens and infra red LEDs provide around the clock optimum performance in demanding lighting conditions. These cameras have an automatic trigger that comes on during low lighting and goes off during normal lighting levels. The max. distance of IR illuminators is 10m. We recommend a max. distance of 6m.

Application Hints And Illumination

Provide even illumination over the scene.

Do not let the camera view any light source direct – both natural and artificial.

Do not create over exposure by using excess lighting levels.

Be alert to the ongoing needs to avoid light pollution and think in terms of energy management.

Remember that when natural light is not available, artificial light must be provided since without light there can be no picture.

APPLICATIONS MATRIX

This matrix covers the following kits:

Ref:

ENTRY LEVEL

Internal system kit 1 fixed	E1
External system kit 2 fixed	E2
Internal/external system kit 3 fixed	E3

INTERMEDIATE LEVEL 1

Internal system kit (A) vari-focal	IA
External system kit (B) vari-focal	IB
Internal/external kit (C) vari-focal	IC

INTERMEDIATE LEVEL 2

Internal system kit (2A) vari-focal	I2A
External system kit (2B) vari-focal	I2B
Internal/external system kit (2C) vari-focal	I2C

There is a large overlap of systems due to the wide nature of the applications that can use CCTV. The following matrix gives a provisional indication of the use of the kits and the maximum installation distance between the cameras & control point (DVR location).

CCTV APPLICATIONS KIT SELECTION	50m max. inst. dist. cameras to control point			50m max. inst. dist. cameras to control point			200m max. inst. dist. cameras to control point		
	E1 int	E2 ext	E3 int/ ext	IA int	IB int	IC int/ ext	I2A int	I2B int	I2C int/ ext
OFFICES Monitoring of staff, entry exit points and key areas	✓	✓	✓	✓	✓	✓	✓	✓	✓
SHOPS Monitoring of back store areas, front shop areas and 'blind areas'	✓	✓	✓	✓	✓	✓	✓	✓	✓
INDUSTRIAL UNITS Monitoring of warehouses, office areas, entry/exits and store areas	✓	✓	✓	✓	✓	✓	✓	✓	✓
DOCTOR / DENTIST PRACTICES Monitoring of waiting areas, surgeries and drugs areas	✓	✓	✓	✓	✓	✓	✓	✓	✓
RESIDENTIAL PERIMETERS		✓	✓		✓	✓		✓	✓
APPROACH ROADS		✓	✓		✓	✓		✓	
SCHOOLS / LIBRARIES				✓	✓	✓	✓	✓	✓
HOSPITALS				✓	✓	✓	✓	✓	✓
HIGH SECURITY RISKS High resolution pictures required for all applications							✓	✓	✓

Easy Installation

The entry level systems kits are available in three different formats depending on the need for internal or external duty working or a mix of both.

In view that these kits come complete with all of the necessary parts and pre-wired cables they are easy to install. All lenses are fixed focus so there are no complicated set up procedures. In addition there can be no problems at the installation stage as the operation of all of the components and the compatibility of the parts to work together as an effective system have been assured.

These entry level systems kits are namely:

- Entry Level: Internal System Kit 1 Fixed
- Entry Level: External System Kit 2 Fixed
- Entry Level: Internal/External System Kit 3 Fixed

The following pages of the guide detail the:

Product Content Specification

This covers the component parts forming the kit of the three different types. Shows a breakdown of the parts and an indication of their roles.

System Overview

An illustration of the parts working in conjunction with each other and a system overview.

System Connections

Details the actual cabling and connection methods. Illustrates the cabling points within the installed system.

Application Hints

Tips in regard to the system installation.

Internal System Kit 1 Fixed

Product content specification

2x Colour mini dome cameras

2x Twisted pair converter kits

1x 4 channel DVR

1x Monitor 14" CRT

2x Power supplies 12V

1x BNC Lead 4 way 1 metre

** 2 additional cameras can be added*

System Overview

This kit is the ideal selection for those installations intended for internal locations. It uses stylish colour mini dome cameras with fixed focus lenses and an angle of view of 87°. They have a maximum working distance between the camera and the control point of 50m and can be used for monitoring activities in a wide range of applications to include the following:

OFFICES: Monitoring of staff, Reception areas, entry and exit points and key locations.

SHOPS: Monitoring of back store areas, front shop areas and blind areas.

INDUSTRIAL UNITS: Monitoring of warehouse or office area, entry and exit points and store areas.

DOCTORS / DENTIST PRACTICES: Monitoring of waiting areas, surgeries and drugs areas.

ENTRY LEVEL SYSTEMS KITS

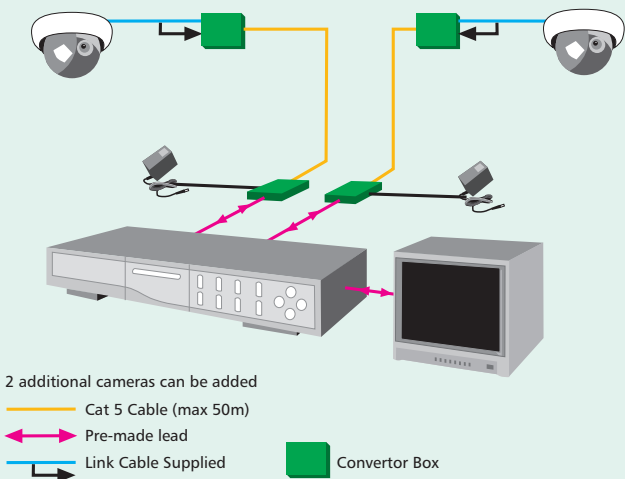

System Connections

Connect the converter box at the control location to the Cat5 cable and the power via the PSU supplied. At the camera end connect the converter to the Cat5 cable. Connect the camera to this converter box via the supplied lead. Power and video are then transmitted across the Cat5 cable max 50mtrs.

At the control DVR connect the camera inputs to the relevant converter box using the cable supplied. Connect the monitor to the main output of the DVR. Connect the DVR to the power supply provided. Connect monitors and all power supplies to the mains supply and switch on.

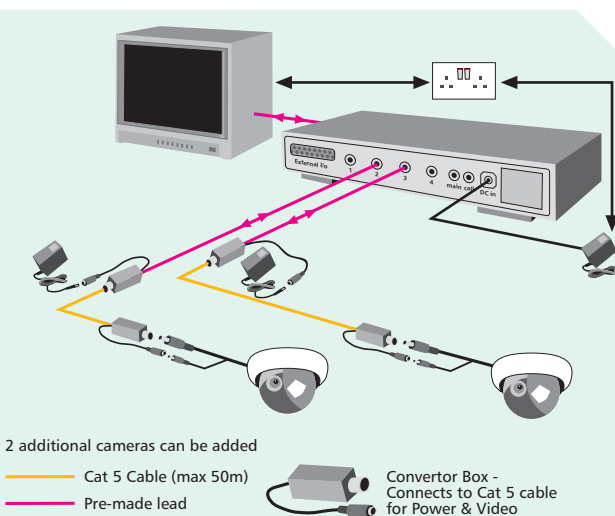

After the system has been connected to the mains supply and switched on together with the power supplies, it will conduct a self test and then display all of the connected cameras.

Application Hints

- The views are classed as general observation. Ideal for monitoring activity in the location
- The cameras can be easily located at the destination point and directed at the scene. There are no complicated set up procedures.
- Do not point the camera directly towards doors or windows. This will affect the picture quality.
- Always install all equipment and components on a secure fixing. Ensure that the cameras are fixed to a secure point and are not subject to vibration.
- Ensure that all connections are made correctly and are secure in an appropriate junction box.
- Always use the supplied power supplies.
- The maximum distance between the control equipment and cameras must not exceed 50m.
- The system has been designed to work on Cat5 cable. Do not use standard twisted pair, multi core or screened cable.
- Always install the cabling in accordance with the relevant electrical standards for cable installations.

External System Kit 2 Fixed

Product Content Specification

2x IR colour/mono cameras

2x Twisted pair converter kits

1x 4 channel DVR

1x Monitor 14" CRT

2x Power supplies 12V

1x BNC Lead 4 way 1 metre

** 2 additional cameras can be added*

System Overview

This kit is the ideal selection for those installations intended for external locations. It uses IR colour/mono cameras with a fixed focus lens. They have a maximum working distance between the camera and the control point of 50m. Their use includes:

OFFICES: Monitoring of staff in low light areas, reception areas, entry and exit gates and key locations, building perimeters. Monitoring of car parking areas and assembly points.

SHOPS: Monitoring of back exit doors, front shop area externally and external loading bays.

INDUSTRIAL UNITS: Monitoring of low light warehouse areas, loading bays and car park areas.

DOCTORS / DENTIST PRACTICES: Monitoring of external entrances and car parking areas.

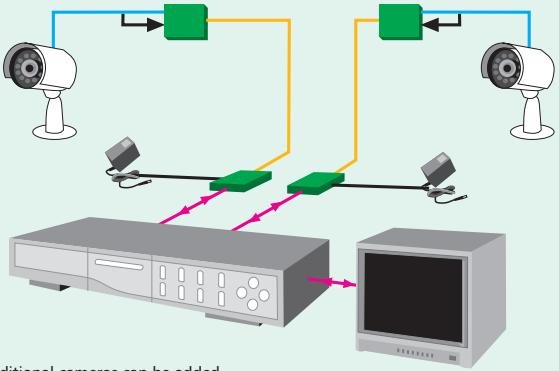

2 additional cameras can be added

— Cat 5 Cable (max 50m)

↔ Pre-made lead

— Link Cable Supplied

■ Converter Box

System Connections

Connect the converter box at the control location to the Cat5 cable and the power via the PSU supplied. At the camera end connect the converter to the Cat5 cable. Connect the camera to this converter box via the supplied lead. Power and video are then transmitted across the Cat5 cable max 50mtrs.

At the control DVR connect the camera inputs to the relevant converter box using the cable supplied. Connect the monitor to the main output of the DVR. Connect the DVR to the power supply provided. Connect monitors and all power supplies to the mains supply and switch on.

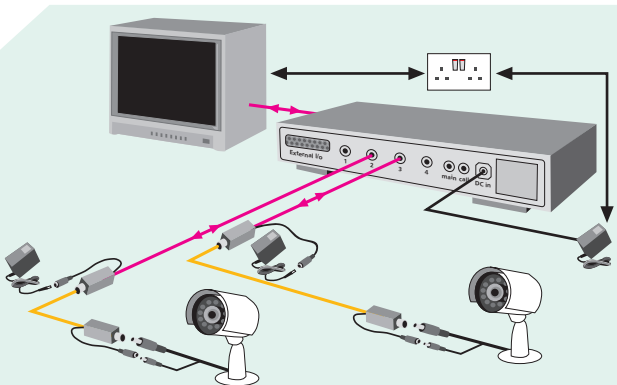

2 additional cameras can be added

— Cat 5 Cable (max 50m)

— Pre-made lead

■ Converter Box - Connects to Cat 5 cable for Power & Video

After the system has been connected to the mains supply and switched on together with the power supplies, it will conduct a self test and display all of the connected cameras. Note that the cameras will automatically switch to monochrome in low light conditions.

Application Hints

- The views are classed as general observation and are ideal for monitoring external activity in the location.
- Always install the camera under a soffit or in a sheltered location that does not suffer the full force of the rain. These cameras are IP65 rated.
- Do not point the camera directly towards sources of light including street lights, floodlights or similar illumination as this will affect the picture quality.
- The effective range of the IR illuminator is 10m. We recommend a max. range of 6m.
- Always install all equipment and components on a secure fixing that are not subject to vibration.
- Ensure that all connections are made correctly and secure in an appropriate junction box. Always use the supplied power supplies
- The maximum distance between the control equipment and cameras must not exceed 50m.
- The system has been designed to work on Cat5 cable. Do not use standard twisted pair, multi core or screened cable.
- Always install the cabling in accordance with the relevant electrical standards for cable installations.

Internal/external System Kit 3 Fixed

Product content specification

2x Colour mini dome cameras

2x IR colour/mono cameras

4x Twisted pair converter kits

1x 4 channel DVR

1x Monitor 14" CRT

4x Power supplies 12V

1x BNC Lead 4 way 1 metre

System Overview

This kit can be specified for those applications which require both internal and external monitoring. It features a mix of stylish colour mini dome fixed focus cameras with a lens angle of 87° and external standard resolution IR colour/mono cameras with a lens angle of 61°. They have a maximum working distance between the camera and the control point of 50m. It can be used in a wide range of monitoring activities such as:

OFFICES, SHOPS, COMMERCIAL INDUSTRIAL AND PUBLIC SERVICE SECTORS: To monitor those areas requiring both internal and external cameras and to track individuals moving between areas.

ENTRY LEVEL SYSTEMS KITS

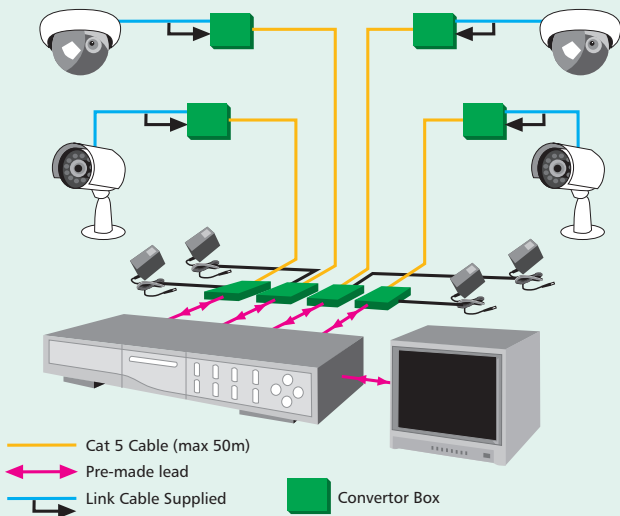

System Connections

Connect the converter box at the control location to the Cat5 cable and the power via the PSU supplied. At the camera end connect the converter to the Cat5 cable. Connect the camera to this converter box via the supplied lead. Power and video are then transmitted across the Cat5 cable max 50mtrs.

At the control DVR connect the camera inputs to the relevant converter box using the cable supplied. Connect the monitor to the main output of the DVR. Connect the DVR to the power supply provided. Connect monitors and all power supplies to the mains supply and switch on.

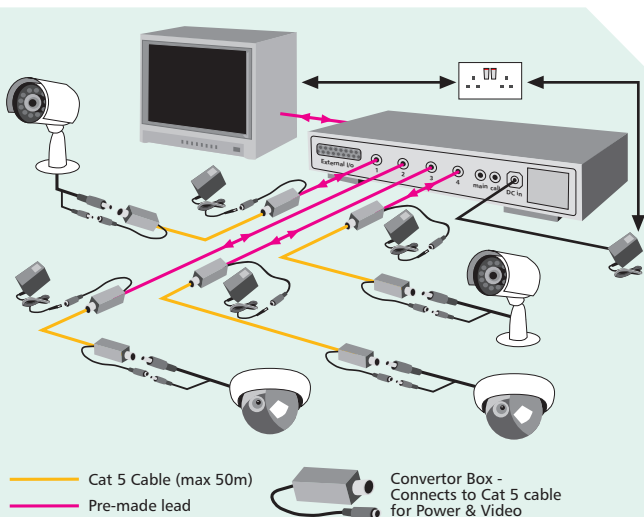

After the system has been connected to the mains supply and switched on together with the power supplies it will conduct a self test and then display all of the connected cameras. Note that the external colour/mono cameras will automatically switch to monochrome in low light conditions.

Application Hints

- The views are classed as general observation and are ideal for monitoring activity in the location. There are no complicated camera set ups.
- Always install the external cameras under a soffit or in a sheltered location that does not suffer the full force of the rain. These are rated IP65.
- Do not point the cameras directly towards sources of light including street lights and floodlights or similar illumination as this will affect the picture quality.
- The effective range of the IR illuminators is 10m. We recommend a max. range of 6m.
- Install all equipment and components on a secure fixing not subject to vibration.
- Ensure that all connections are made correctly and secure in an appropriate junction box. Always use the supplied power supplies.
- The maximum distance between the control equipment and cameras must not exceed 50m.
- The system has been designed to work on Cat5 cable. Do not use standard twisted pair, multi core or screened cable.
- Always install the cabling in accordance with the relevant electrical standards for cable installations.

Enhanced Installation

The intermediate level systems kits are available at two levels classified as Level 1 and Level 2. There are three different formats at each level.

These kits come complete with all of the necessary parts and pre-wired cables and allow the installer to fit enhanced installations that feature a wide range of functions.

In view that these systems are purchased in kit form this provides an assurance to the installer of the compatibility of the parts and their ability to work as an effective system.

Vari-focal lenses are supplied with all kits. These allow the focal length to be manually adjusted slightly during the installation so that the field of view or scene can be altered to give the optimum picture at the monitor.

These intermediate level system kits include high quality components that are required to form enhanced systems with advanced features.

These kits are identified as:

- Intermediate Level 1:
Internal System Kit (A) Vari-focal.
- Intermediate Level 1:
External System Kit (B) Vari-focal.
- Intermediate Level 1:
Internal/external Kit (C) Vari-focal.

- Intermediate Level 2:
Internal System Kit (2a) Vari-focal.
- Intermediate Level 2:
External System Kit (2b) Vari-focal.
- Intermediate Level 2:
Internal/external System Kit (2c) Vari-focal.

Maximum working distance between the camera and the system control point.

Intermediate Level 1 Kits

Use cameras that are powered close to the system control point i.e. DVR location. **Maximum working distance between camera and control point 50m.**

Intermediate Level 2 Kits

Use cameras that are powered locally i.e. close to the camera position. **Maximum working distance between camera and control point 200m.**

The following pages of the guide detail the:

Product Content Specification

This covers the component parts forming the kit of the three different types. The product content specifications show a breakdown of the parts and give an indication of their roles. It will be noted that in these specifications there is a wide use of different components for the different kit levels. These include the use of different DVR control equipment and the monitors used to view the final images. The monitors may be traditional CRT or new generation LCD screens. MPEG4 DVR's are capable of generating TV quality images at a low bandwidth.

System Overview

An illustration of the parts working in conjunction with each other together with a system overview.

System Connections

Details the actual cabling and connection methods. Illustrates the cabling points within the installed system.

Application Hints

Tips in regard to the system installation. The application hints vary between the different levels.

Internal System Kit (A) Vari-focal

Product content specification.

2x Colour mini dome cameras Vari-focal

2x Twisted pair converter kits

1x 4 channel DVR

1x Monitor 14" CRT

2x Power supplies 12V

1x BNC Lead 4 way 1 metre

** 2 additional cameras can be added*

System Overview

This kit is ideal for internal installations requiring compact stylish colour mini dome cameras with a vari-focal lens and a high specification. The angle of view can be selected to give a wide angle or a relatively narrow field of view. They have a maximum working distance between the camera and the DVR control point of 50m.

This kit can be used for monitoring activities in a wide range of applications that require high resolution pictures with fine detail.

The vari-focal lens provides a margin of adjustment for the installer to set the angle of view of the scene at the lens. In addition the camera direction towards the scene can be easily adjusted using the pan, tilt and rotate mechanism. The cameras are high resolution enabling the fine detail of the scene to be displayed at the monitor.

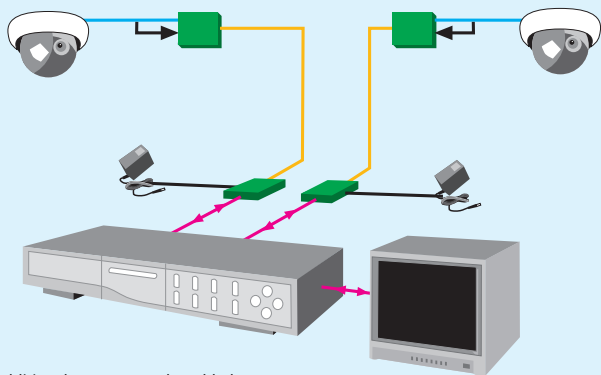

2 additional cameras can be added

— Cat 5 Cable (max 50m)

↔ Pre-made lead

→ Link Cable Supplied

■ Converter Box

System Connections

Connect the converter box at the control location to the Cat5 cable and the power via the PSU supplied. At the camera end connect the converter to the Cat5 cable. Connect the camera to this converter box via the supplied lead. Power and video are then transmitted across the Cat5 cable max 50mtrs.

At the control DVR connect the camera inputs to the relevant converter box using the cable supplied. Connect the monitor to the main output of the DVR. Connect the DVR to the power supply provided. Connect monitors and all power supplies to the mains supply and switch on.

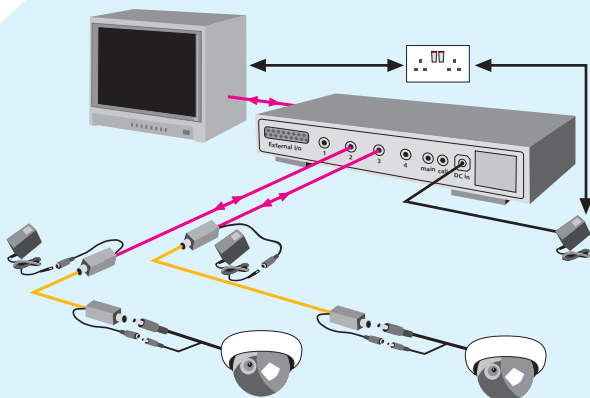

2 additional cameras can be added

— Cat 5 Cable (max 50m)

↔ Pre-made lead

■ Converter Box - Connects to Cat 5 cable for Power & Video

After the system has been connected to the mains supply and switched on together with the power supplies it will conduct a self test and then display all of the connected cameras.

Application Hints

- These systems use high resolution colour cameras so attention must be made to the local lighting levels within the premises and the seasonal differences at all times that the cameras are operational.
- Do not point the camera directly towards doors or windows. This will affect the picture quality.
- Always install all equipment and components on a secure fixing. Ensure that the cameras are fixed to a secure point and are not subject to vibration.
- The dome camera has a manual pan/tilt/rotation mechanism so it can be easily directed towards the actual target area or the required scene.
- The focal length of the lens can be adjusted by a small margin during the installation process and then set to give the optimum angle of view at the monitor.
- Ensure that all connections are made correctly and secure in an appropriate junction box.
- Always use the supplied power supplies.
- The maximum distance between the control equipment and cameras must not exceed 50m.
- The system has been designed to work on Cat5 cable. Do not use standard twisted pair, multi core or screened cable.
- Always install the cabling in accordance with the relevant electrical standards for cable installations.

External System Kit (B) Vari-focal

Product Content Specification

2x IR vari-focal colour/mono cameras

2x Twisted pair converter kits

1x 4 channel DVR

1x Monitor 14" CRT

2x Power supplies 12V

1x BNC Lead 4 way 1 metre

** 2 additional cameras can be added*

System Overview

This kit can be specified for those external installations that demand the use of high resolution IR colour/mono cameras with a vari-focal lens. The angle of view can be selected to give a wide angle or a relatively narrow field of view. They have a maximum working distance between the camera and the control point of 50m

This kit can be used for monitoring activities in a wide range of applications that require high resolution pictures with fine detail. The cameras operate in colour during the day and in monochrome during low light conditions and provide pictures with fine detail at the monitor. The vari-focal lens provides a margin of adjustment for the installer to set the angle of view of the scene.

INTERMEDIATE LEVEL SYSTEMS KITS

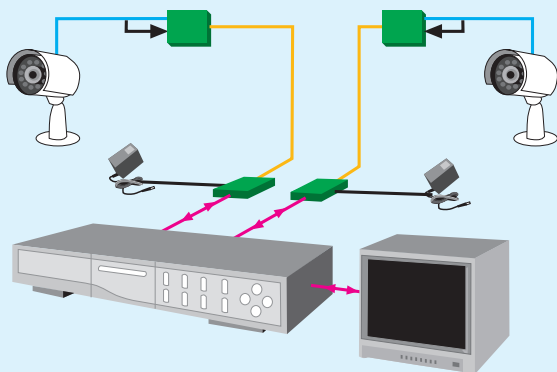

2 additional cameras can be added

— Cat 5 Cable (max 50m)

↔ Pre-made lead

— Link Cable Supplied

Converter Box

System connections

Connect the converter box at the control location to the Cat5 cable and the power via the PSU supplied. At the camera end connect the converter to the Cat5 cable. Connect the camera to this converter box via the supplied lead. Power and video are then transmitted across the Cat5 cable max 50mtrs.

At the control DVR connect the camera inputs to the relevant converter box using the cable supplied. Connect the monitor to the main output of the DVR. Connect the DVR to the power supply provided. Connect monitors and all power supplies to the mains supply and switch on.

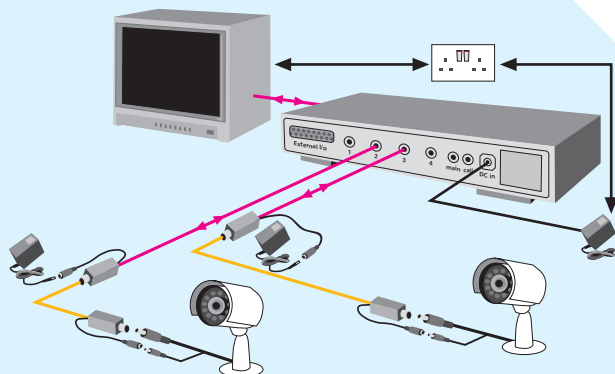

2 additional cameras can be added

— Cat 5 Cable (max 50m)

— Pre-made lead

Converter Box -
Connects to Cat 5 cable
for Power & Video

After the system has been connected to the mains supply and switched on together with the power supplies it will conduct a self test and then display all of the connected cameras.

Note the cameras will automatically switch to monochrome during low light conditions.

Application Hints

- Always install the cameras under a soffit or in a sheltered location that does not suffer the full force of the rain. The cameras are rated as IP65.
- Do not point the camera directly towards bright light sources as this will affect the picture quality.
- The effective range of the IR illuminators is 10m. We recommend a max. range of 6m.
- Always install all equipment and components on a secure fixing. Ensure that the cameras are fixed to a secure point and are not subject to vibration.
- The focal length of the lens can be adjusted to a small margin during the installation process and then set to give the optimum angle of view at the monitor.
- Ensure that all connections are made correctly and secure in an appropriate junction box.
- The maximum distance between the control equipment and cameras must not exceed 50m.
- The system has been designed to work on Cat5 cable. Do not use standard twisted pair, multi core or screened cable.
- Always install the cabling in accordance with the relevant electrical standards for cable installations.

Internal/external System Kit (C) Vari-focal

Product content specification

2x Colour mini dome Vari-focal cameras

2x IR vari-focal colour/mono cameras

4x Twisted pair converter kits

1x 4 channel DVR

1x Monitor 14" CRT

4x Power supplies 12V

1x BNC Lead 4 way 1 metre

System Overview

This kit is intended for those applications which require both internal and external monitoring with vari-focal lenses and high specification equipment. The angles of view of all the cameras can be adjusted to give a wide angle or a relatively narrow field of view. The internal cameras are compact colour domes. The external cameras are high resolution IR colour/mono cameras. They have a maximum working distance between the camera and the control point of 50m.

INTERMEDIATE LEVEL SYSTEMS KITS

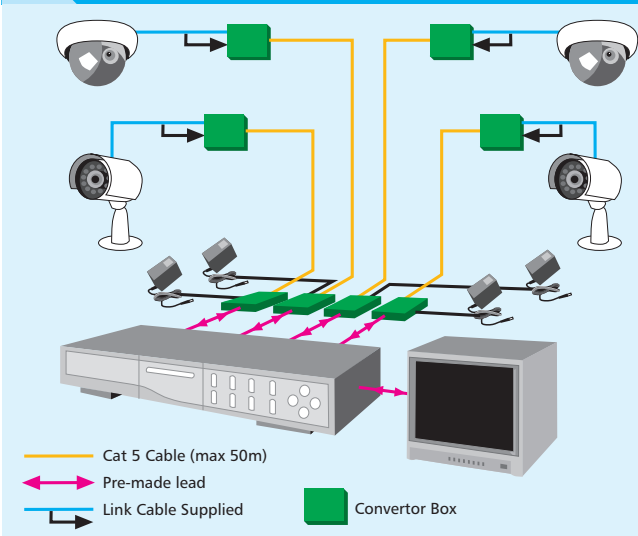

System connections

Connect the converter box at the control location to the Cat5 cable and the power via the PSU supplied. At the camera end connect the converter to the Cat5 cable. Connect the camera to this converter box via the supplied lead. Power and video are then transmitted across the Cat5 cable max 50mtrs.

At the control DVR connect the camera inputs to the relevant converter box using the cable supplied. Connect the monitor to the main output of the DVR. Connect the DVR to the power supply provided. Connect monitors and all power supplies to the mains supply and switch on.

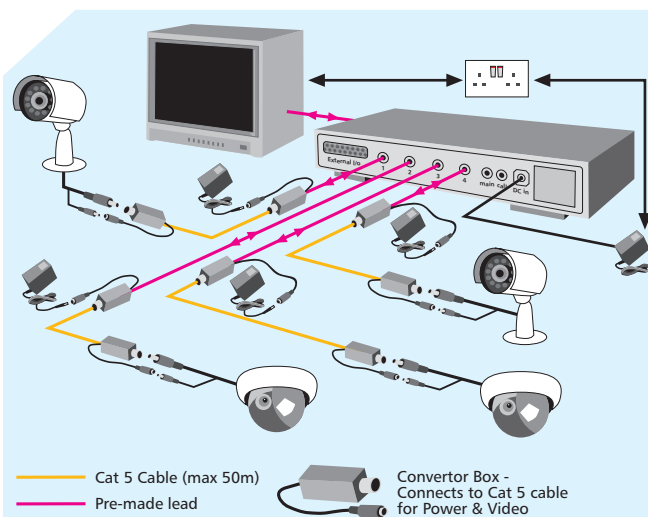

After the system has been connected to the mains supply and switched on together with the power supplies it will conduct a self test and then display all of the connected cameras. Note that the external colour/mono cameras will automatically switch to monochrome in low light conditions.

Application Hints

- These systems use high resolution colour cameras so attention must be made to the local lighting levels and the seasonal differences at all times that the cameras are operational.
- Do not point the camera directly towards doors or windows or sources of light including street lights and floodlights. Avoid strong light sources in the picture.
- Always install the external cameras under a soffit or in a sheltered location that does not suffer the full force of the rain. These are rated IP65.
- The effective range of the IR illuminators is 10m. We recommend a max. range of 6m.
- Always install all items of equipment and components on a secure fixing that are not subject to vibration. Only use the supplied power supplies.
- The focal length of the lens can be adjusted to a small margin during the installation process and then set to give the optimum angle of view at the monitor.
- Ensure that all connections are made correctly and secure in an appropriate junction box. Install the cabling in accordance with the relevant electrical standards for cable installations.

Level 2: Internal System Kit (2a) Vari-focal

Product Content Specification

2x Colour mini dome cameras Vari-focal

4x Twisted pair converter kits

1x 4 channel DVR

1x LCD

2x Power supplies 12V

1x BNC Lead 4 way 1 metre

** 2 additional cameras can be added*

System Overview

This kit is the ideal for internal those applications which have a requirement for compact stylish colour mini dome cameras with a vari-focal lens and to a high specification. These kits feature an advanced DVR (MPEG4) and a new generation LCD monitor. The cameras are powered locally. The maximum working distance between the cameras and the control point is 200m.

This kit can be used for monitoring activities in a wide range of applications that require high resolution pictures with fine detail.

The vari-focal lens provides a margin of adjustment for the installer to set the angle of view of the scene at the lens. The cameras are high resolution enabling the fine detail of the scene to be displayed at the monitor.

Offices, shops, commercial and industrial areas together with public buildings can all benefit from the use of the features included in this intermediate level 2 kit.

INTERMEDIATE LEVEL SYSTEMS KITS

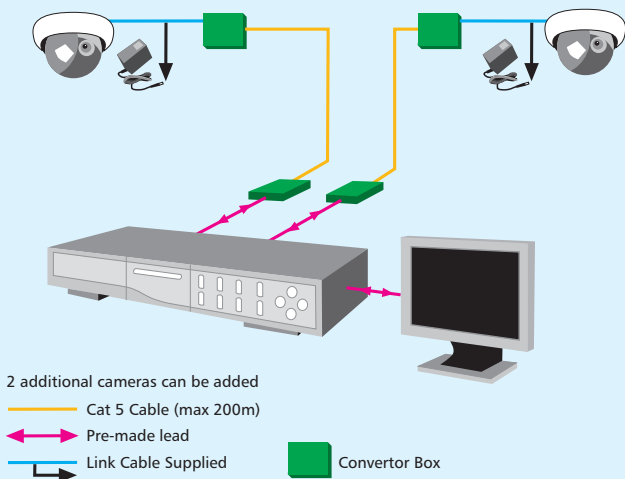

System Connections

Connect the converter box at the control location to the Cat5 cable. At the camera end connect the converter to the Cat5 cable. Then connect the camera to this converter box and to the power via the power supply and the supplied lead. Video is transmitted across the Cat5 cable system max 200mtrs.

At the control DVR connect the camera inputs to the relevant converter box using the cable supplied. Connect the monitor to the main output of the DVR. Connect the DVR to the power supply provided. Connect monitors and all power supplies to the mains supply and switch on.

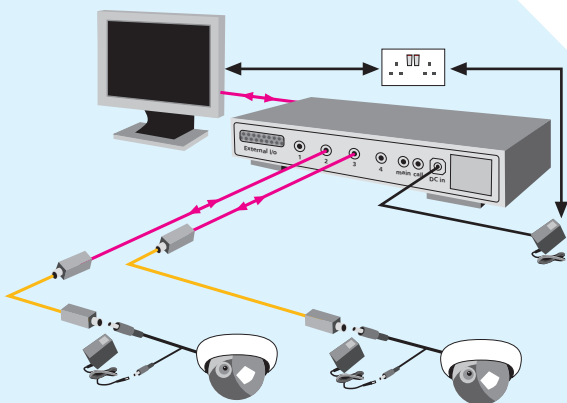

After the system has been connected to the mains supply and switched on together with the power supplies it will conduct a self test and then display all of the connected cameras.

Application Hints

- These systems use colour cameras that are powered locally at the camera head.
- Attention must be made to the local lighting levels and the seasonal differences at all times that the cameras are operational.
- Do not point the camera directly towards doors or windows. This will affect the picture quality.
- Always install all equipment and components on a secure fixing that are not subject to vibration.
- The dome camera has a manual pan/tilt/rotation mechanism so that the camera can be easily directed towards the actual target area or scene required of the application.
- The focal length of the lens can be adjusted to a small margin during the installation process and then set to give the optimum angle of view at the monitor.
- Ensure that all connections are made correctly and secure in an appropriate junction box.
- Always use the supplied power supplies.
- The maximum distance between the control equipment and cameras must not exceed 200m.
- The system has been designed to work on Cat5 cable. Do not use standard twisted pair, multi core or screened cable.
- Always install the cabling in accordance with the relevant electrical standards for cable installations.

Level 2. External System Kit (2b) Vari-focal

Product Content Specification

2x IR vari-focal colour/mono cameras

2x Twisted pair converter kits

1x 4 channel DVR

1x LCD

2x Power supplies 12V

1x BNC lead 4 way 1 metre

** 2 additional cameras can be added*

System Overview

This kit is the ideal selection for external installations that demand the use of high specification IR colour/mono cameras with a vari-focal lens. The system employs an advanced DVR (MPEG4) and a new generation LCD monitor. The cameras are powered locally. The maximum working distance between the cameras and the control point is 200m.

This kit can be used for external monitoring activities in a wide range of applications that require high resolution pictures with fine detail. The cameras operate in colour during the day and in monochrome during low light conditions so as to obtain the best possible resolution of the picture at the monitor. The vari-focal lenses provides a margin of adjustment for the installer to set the angle of view of the scene at the lens. The cameras are high resolution and provide images with fine detail at the monitor.

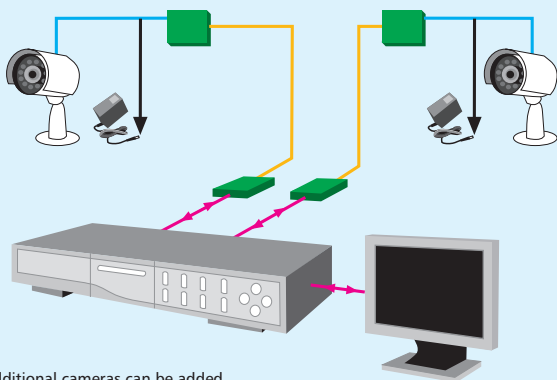

2 additional cameras can be added

— Cat 5 Cable (max 200m)

— Pre-made lead

— Link Cable Supplied

Converter Box

System Connections

Connect the converter box at the control location to the Cat5 cable. At the camera end connect the converter to the Cat5 cable. Then connect the camera to this converter box and to the power via the power supply and the supplied lead. Video is transmitted across the Cat5 cable system max 200mtrs.

At the control DVR connect the camera inputs to the relevant converter box using the cable supplied. Connect the monitor to the main output of the DVR. Connect the DVR to the power supply provided. Connect monitors and all power supplies to the mains supply and switch on.

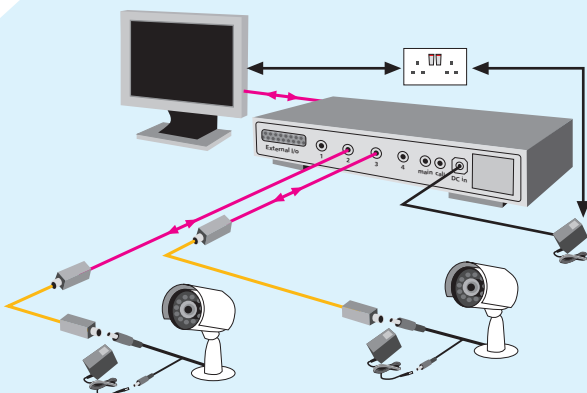

2 additional cameras can be added

— Cat 5 Cable (max 200m)

— Pre-made lead



Converter Box -
Connects to Cat 5
cable for Video

After the system has been connected to the mains supply and switched on together with the power supplies it will conduct a self test and then display all of the connected cameras. Note the cameras will automatically switch to monochrome during low light conditions

Application Hints

- These systems use colour IR cameras that are powered locally at the camera.
- Always install the cameras under a soffit or in a sheltered location that does not suffer the full force of the rain.
- Do not point the camera directly towards bright light sources as this will affect the picture quality.
- Always install all equipment and components on a secure fixing. Ensure that the cameras are fixed to a secure point and are not subject to vibration.
- The focal length of the lens can be adjusted to a small margin during the installation process and then set to give the optimum angle of view at the monitor.
- Ensure that all connections are made correctly and secure in weatherproof junction boxes.
- The max. distance of IR illuminators is 10m. We recommend a max. distance of 6m.
- Always use the supplied power supplies.
- The maximum distance between the control equipment and cameras must not exceed 200m.
- The system has been designed to work on Cat5 cable. Do not use standard twisted pair, multi core or screened cable.
- Always install the cabling in accordance with the relevant electrical standards for cable installations.

Level 2: Internal/external System Kit (2c) Vari-focal

Product Content Specification

2x Colour mini dome Vari-focal cameras

2x IR vari-focal colour/mono cameras

4x Twisted pair converter kits

1x 4 Ch Twisted pair converter

1x 4 channel DVR

1x LCD Monitor

4x Power supplies 12V

1x BNC Lead 4 way 1 metre

System Overview

This kit is an ideal choice for those applications which require both internal and external monitoring with vari-focal lenses, external IR colour/ mono cameras and high specification equipment. It features an advanced DVR (MPEG4) and a new generation LCD monitor. The cameras are powered locally. The maximum working distance between the cameras and the control point is 200m. All cameras are high resolution and provide images with fine detail.

INTERMEDIATE LEVEL SYSTEMS KITS

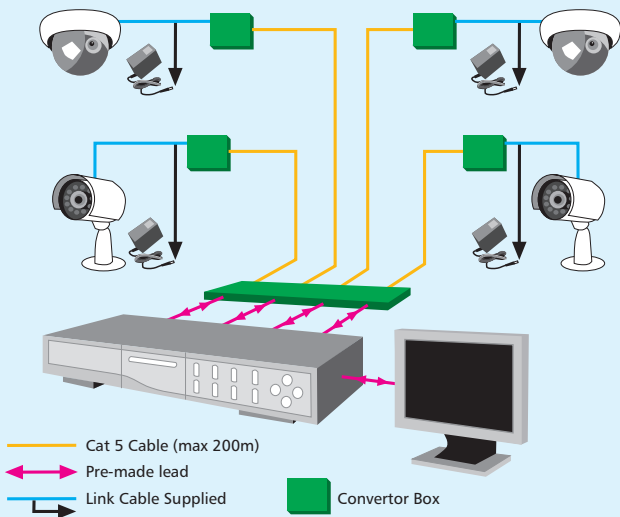

System Connections

Connect the converter box at the control location to the Cat5 cable. At the camera end connect the converter to the Cat5 cable. Then connect the camera to this converter box and to the power via the power supply and the supplied lead. Video is transmitted across the Cat5 cable system max 200mtrs.

At the control DVR connect the camera inputs to the relevant converter box using the cable supplied. Connect the monitor to the main output of the DVR. Connect the DVR to the power supply provided. Connect monitors and all power supplies to the mains supply and switch on.

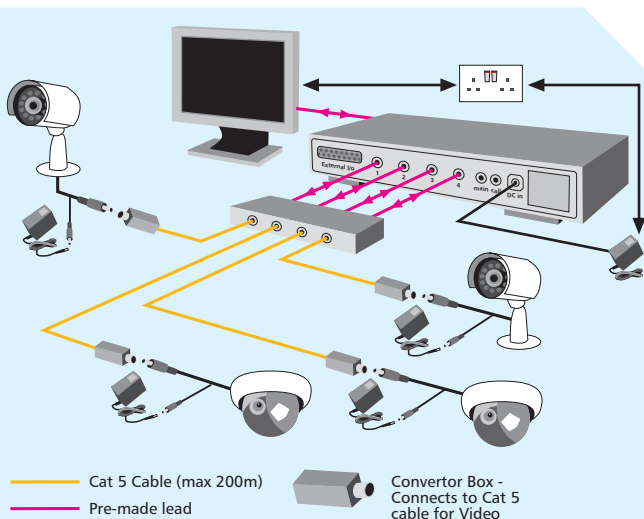

After the system has been connected to the mains supply and switched on together with the power supplies it will conduct a self test and then display all of the connected cameras. Note that the external colour/mono cameras will automatically switch to monochrome in low light conditions.

Application Hints

- Always install the external cameras under a soffit or in a sheltered location that does not suffer the full force of the rain.
- Do not point the cameras directly towards sources of light including street lights and floodlights and avoid strong light sources in your picture.
- The max. distance of IR illuminators is 10m. We recommend a max. distance of 6m.
- Always install all equipment and components on a secure fixing that are not subject to vibration.
- Ensure that the cameras are fixed to a secure point and are not subject to vibration.
- The focal length of the lens can be adjusted to a small margin during the installation process and then set to give the optimum angle of view at the monitor.
- Make sure that all connections are connected correctly and secure in the supplied weather-resistant junction boxes and the cabling is installed in accordance with the relevant electrical standards for cable installations.
- Make sure that all connections are connected correctly and secure and in an appropriate junction box.
- Only use the supplied cable as the system has been designed to use Cat5 cable only.
- Do not use standard twisted pair, multi core or screened cable. The maximum distance between the cameras and control equipment must not exceed 200m.

Component Selection

The first part of the selection process involves specifying the cameras/lenses and then determining what is the most effective DVR.

The flow charts illustrate how an initial selection of parts can be made by using the working distance between the control point and the cameras as a design guide which is based on the system size. The flow charts cover the camera, DVR and monitor selection plus further camera selection criteria.

Use the following options:

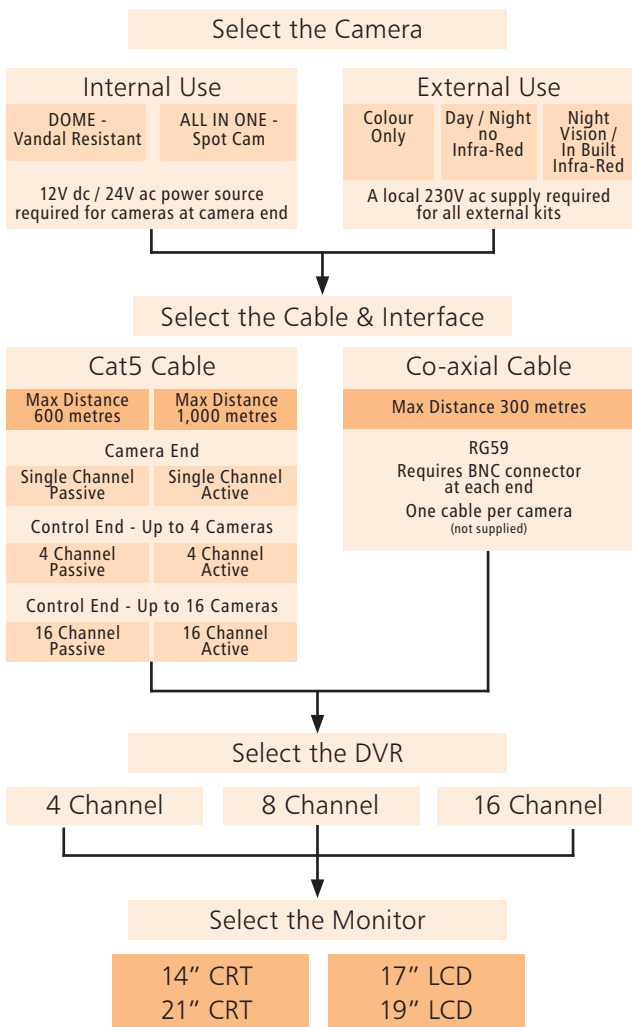

Selection Matrix

Cameras Internal	Please Tick	Cameras External	Please Tick
Internal Dome		Colour only	
Vandal Dome		Day / Night no Infra-Red	
All in one		Night Vision	
12v DC Power Supply		230v AC Power Supply	
24v AC Power Supply			
Cat5 - Short Distance		Cat5 - Long Distance	
Single Channel Passive		Single Channel Active	
4 Channel Passive		4 Channel Active	
16 Channel Passive		16 Channel Active	
DVR		DVR	
4 Channel DVR		Select no more than 4 cameras	
8 Channel DVR		Select no more than 8 cameras	
16 Channel DVR		Select no more than 16 cameras	
CRT Monitor		LCD Monitor	
14" Monitor		17" Monitor	
21" Monitor		19" Monitor	

Component Descriptions

Cameras

INTERNAL DOME - High resolution Colour dome camera with 3-9mm Vari-focal lens 12VDC or 24Vac internal use only

VANDEL RESISTANT DOME - High resolution vandell resistant Colour dome camera with 3-9mm Vari-focal lens 12VDC or 24Vac internal external use

ALL IN ONE CAMERA - High resolution Colour camera with 2.8-10mm Vari-focal lens 12VDC or 24Vac internal use including cable managed wall bracket

COLOUR KIT - Pre built ext camera kit include high resolution colour camera 2.8-12mm vari-focal auto iris lens Ext camera housing and wall bracket

DAY/NIGHT KIT - Pre built ext camera kit include high resolution Day/night camera 3.5-10.5mm vari-focal auto iris lens Ext camera housing and wall bracket

NIGHT VISION KIT - Pre built ext camera kit include high resolution Day/night camera 3.5-10.5mm vari-focal auto iris lens Ext camera housing and wall bracket and IR Illumination

Cables

SINGLE CHANNEL PASSIVE - Single channel interface from camera to Cat5 cable maximum distance 200 meters Passive device

4 CHANNEL PASSIVE - 4 channel interface from Cat5 cable to control equipment maximum distance 200 meters Passive device

16 CHANNEL PASSIVE - 16 channel interface from Cat5 cable to control equipment maximum distance 200 meters Passive device

SINGLE CHANNEL ACTIVE - Single channel interface from camera to Cat5 cable maximum distance 600 meters Active device 12V dc required

4 CHANNEL ACTIVE - 4 channel interface from Cat5 cable to control equipment maximum distance 600 meters Active device 12V dc required

16 CHANNEL ACTIVE - 16 channel interface from Cat5 cable to control equipment maximum distance 600 meters Active device 12V dc required

DVR

4 CHANNEL DVR - 4 Channel DVR c/w DVD writer and 160GB hard Drive. Networkable and USB download.

8 CHANNEL DVR - 8 Channel DVR c/w DVD writer and 250GB hard Drive. Networkable and USB download.

16 CHANNEL DVR - 16 Channel DVR c/w DVD writer and 500GB hard Drive. Networkable and USB download.

Monitor

17" LCD / 14" CRT - Ideal for 4-8 channel DVR

19" LCD / 21" CRT - Ideal for 4-8-16 channel DVR or when larger images are required

APPLICATION EXAMPLES

These application examples are effectively installation considerations that apply to any CCTV system.

It is to be understood that a CCTV system is made up from a number of components that themselves must be installed in accordance with certain practices if the final system is to work as intended.

The typical examples shown in the application examples give prompts to help the installer to obtain the best possible results from the proposed system and to avoid any pitfalls in the installation process. They can be seen as do's ✓ and don'ts ✗ in terms of the installation practices to be carried out.

The Application examples are set out against the following:

Camera/lens

Cables

Recording and monitoring equipment

Illumination

Camera/Lens

✓ Install the camera on a solid surface which is not subject to vibration.

✓ Beware of seasonal differences in regard to bright sunshine.

✓ Install the camera in a sheltered location.

✓ Use the supplied power supplies, cables and connectors to make up the connections to the cameras.

✓ Take time setting up and adjusting the camera and always confirm with the client what the actual scene or target will be.

✗ Never point the camera at windows, doors or strong sources of light.

✗ Don't subject external cameras to the full force of the rain.

✗ Don't forget to check with the camera specification to establish if it is to be powered locally at the camera head or at the control point using the system power supply.

✗ Never overlook the fact that there is a need to make a record of every camera position in the system log and of the scenes.

Cables

- ✓ Do understand that all of the components covered by these systems have been designed to work in conjunction with the supplied cables and to a quoted maximum working distance.
- ✓ Appreciate the reason for using Cat5 which is a networking cable and used to transmit the video and power. This facilitates a fast and easy installation. It is terminated with RJ45 connectors.
- ✓ Ensure that the cables are secure and can not be disturbed at the control point location.
- ✓ Install the cables in accordance with relevant electrical standards and wiring regulations.
- ✗ Don't use standard twisted pair, multicore or screened cable as an alternative to Cat5 cable.
- ✗ Never stretch or bend any cables excessively.
- ✗ Don't attempt to use different wiring formats other than those specified.
- ✗ Never attempt to install cabling longer than the maximum distance specified for the system i.e. the cables running between the cameras and control point DVR.

Recording and monitoring equipment

- ✓ Only use the supplied adaptor and power cord for the DVR at the control point.
- ✓ Pay attention to the connection of the cameras (video sources) when connecting them to the video input terminals.
- ✓ Pay attention to the programming of the DVR. In particular it is important to select the most appropriate recording mode and the quality of the recording images.
- ✓ Use the External I/O for control remotely by an external device or control system such as a video web server.
- ✓ Ensure that the monitor termination switch is correctly set.
- ✗ Don't forget to allow for system expansion when choosing the DVR. Select the correct number of video signal channels and always plan ahead.
- ✗ Never overlook the fact that the brightness and contrast must be set at the monitor so that the viewer can see as many picture details as possible.
- ✗ Don't assume that the client is familiar with the operation of the recording and monitoring equipment – always check that they are familiar!

Illumination

- ✓ Understand that without light there can be no picture.
- ✓ Provide even illumination over the scene.
- ✓ Recognise the quoted range for external cameras with infra red illumination.
- ✓ Ensure that artificial lighting is installed for those periods when natural light is not available.
- ✓ Try to use existing lighting if at all possible.
- ✗ Never create over exposure by using excess lighting levels.
- ✗ Don't let the camera view the light source direct as this will cause bright patches or light spots.
- ✗ Don't use manual iris lenses with installations which have changing light levels. Specify an auto iris lens as the correct selection.
- ✗ Never overlook light pollution as when installing overt lighting only true white light will allow full colour definition.
- ✗ Don't neglect the need for maintenance to cover any lighting that forms an essential part of the CCTV scheme.

The Data Protection Act introduced in 1984 did not originally require CCTV systems to be registered however the updated Act which came into effect in 2000 did have an influence on the processing of CCTV data in regard to a living individual. This is because of the rapid development of CCTV and its ability to process data. Nevertheless not all CCTV systems need to be compliant with the Act.

There are three main considerations:

Tracking of Individuals

Are the cameras operated remotely with a facility to pan, tilt and zoom in order to track and observe individuals?

Behaviour of the Individual

Are the images from the CCTV to be used to observe the behaviour of an individual for business purposes or to assess the performance of staff?

Third Party Use

Will the CCTV images be given over to a third party other than official law enforcement parties such as the police?

If the answer to all of the three main considerations is 'no' the CCTV system would not be expected to fall within the scope of the Act. However if the system is covered there is an obligation to process the personal data fairly and lawfully. It also places a liability on the installer to carry out certain practices,

If the installation falls within the scope of the Act this means that the installer must:

Fit appropriately sized signs in and around the areas where the cameras are to be located in order to inform people of the existence of the cameras and for what purpose they are being used.

Include the name of the data controller and contact details.

Remember also that under the Human Rights Act cameras must not target private dwellings or grounds.

Full details can be found at www.cbceurope.com.

THE OPERATIONAL REQUIREMENT

When setting up your equipment and carrying out surveillance under Home Office guidelines there is a need to fulfil the 'Operational Requirement'. This is required for evidential purposes and relates to the Monitoring, Detection, Recognition and Identification of the target on the monitor screen.

Monitor

The target size of a target for monitoring is generally 5% of the monitor screen. Ideal for monitoring human or vehicle traffic flows.

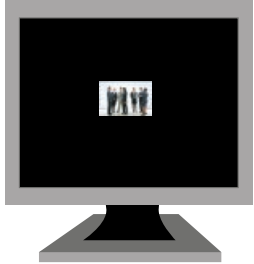

Detect

To obtain best results for electronic detection purposes the picture size of the target should be no less than 10% of screen size.



Recognise

For recognition the picture size on the monitor should be no less than 50% of the screen. This value can be used to recognise a target such as a 'known person'.



Identify

It is recommended that the target size should be 120% of the screen size. This means for example, the face and body of a grown human to the knees but not the full height inclusive of legs!



Handover and Preventative Maintenance

As with all electrical installations there are a number of issues to be upheld. These are in regard to the handover of the system to the client and the establishing of a maintenance schedule.

The Handover of the System Involves:

- Going through the system specification in detail
- Identifying the data in the documentation
- Showing the location of every item of equipment
- Indicating the view of every camera
- Demonstrating the use of the system
- Illustrating the recording procedures
- Activating all equipment
- If telemetry is included demonstrating all aspects of its role

The Maintenance of the System Should:

- Be based on the BSIA Code of Practice 109
- Be made within 12 months of the completion of the installation (known as a Level 1 visit since it is a basic requirement)
- Involve a check to verify that the system complies with the system specified at the original handover
- Confirm that the quality of the image from every camera remains satisfactory.
- Prove that environmental changes have not been made that can have an effect on the system

Glossary of Terms

AMBIENT LIGHT	General light level of a given area or scene.
ANALOGUE	When discussed in video terms it is the representation of a camera scene translated into electronic terminology.
APERTURE	The area of the lens that collects or gathers the light. Just as the human pupil dilates and expands so does the iris of a lens, in effect controlling the size of the aperture and hence the amount of light passing through.
ASPHERICAL LENS	Aspherical lenses have reduced the spherical aberration that exists in all conventional lenses. This allows a larger area of the lens to be used, thus increasing the effective aperture.
AUTOMATIC IRIS	A lens that automatically adjusts to the varying lighting conditions to allow the correct amount of light to fall upon the imaging device.
BACK FOCUS	The mechanical adjustment on a camera that moves the imaging device in relation to the lens to compensate for different back focal lengths of lenses.
B.L.C. (BACK LIGHT COMPENSATION)	Electronically compensates for high lights to enable silhouetted scenes to give more detail.
BNC	Video connector used in CCTV installations.
CAMERA HOUSINGS	A full range of housings is on offer for cameras. These provide protection against the environment, particularly for externally mounted devices, and for those applications where vandalism can occur.
CCTV	A Closed Circuit Television System which is for private purposes only, and not for public or general broadcasting.

DATA CABLE	Cable used for transmitting low level signals between system units.
DEPTH OF FIELD	The proportion of view that is in correct focus. The depth of field decreases when the focal length is longer or the object distance is shorter.
DIGITAL SIGNAL	An analogue signal that has been converted (A/D) to a digital format - binary - in order that it can be processed by a micro-processor (for example used in multiplexing and video transmission equipment).
DUPLEX	Used in multiplexing terminology whereby two single (simplex) units are assembled in one unit enabling the system to record and display simultaneously.
DVR	Digital video recorder. Used to store video information in digital form as opposed to analogue recording.
FIELD OF VIEW	The relationship between the angle of view and the distance of the object from the lens.
FOCAL LENGTH	The distance between the secondary principal point in the lens and the plane of the imaging device. The longer the focal length, the narrower is the angle of view.
FRAME	Is the combination of two fields. 25 frames are created every second. Television pictures are made up of 25 frames per second.
HARDWIRED	Direct cables connected from one electronic product to another. Often used in the simple control of remote equipment.
ILLUMINANCE	The measurement of light in lumens per square metre. The unit of which is the Lux.
INFRARED	The range of radiated waves generally accepted between 700nm (nanometres) and 1000nm. It is light which is invisible to the human eye but which the monochrome camera can 'see'.

INFRARED LIGHTING Lighting units which provide infrared illumination for infrared sensitive cameras. The energy is produced from LEDs or incandescent lamps with the appropriate filters to cut out the visible light. Typical pass wavelength filters are 715 and 850 nm.

INTEGRAL CAMERAS Give high resolution performance using a compact camera/lens combination for sites where the aesthetics of the camera is critical to the interior design.

IRIS The mechanism within a lens that is adjusted to vary the amount of light falling upon the imaging device.

LINE POWERED A camera in which the power is supplied along the same cable as the video information. Tends to be used for small cable runs.

LUX The unit of measurement of light. It is the metric measurement of light striking a surface.

MONOCHROME Only one colour. In CCTV this means a black and white system.

MULTIPLEXER (TIME DIVISION)

An electronic product that can accept a number of camera inputs and record or/and display them almost simultaneously (time shared). These devices offer a range of screen displays. There are two main types:

SIMPLEX: Can record or playback. It is limited to recording full screen images when viewing live pictures in a screen layout.

DUPLEX: A double unit as it can record and display a multiscreen.

MULTIPLEXING The process by which two or more signals are transmitted over a single communications link. Examples include time sharing (video) and wavelength division.

P.A.L. (PHASE ALTERNATE LINE)

Colour television system used throughout many countries of the world with a supply voltage in the order of 200 - 250 Volts at a frequency 50 Hz.

PAN TILT AND ZOOM (PTZ) ASSEMBLIES

A device that will move a camera horizontally and vertically from a remote control point. These are fully functional assemblies which enable a camera to be rotated and tilted and also to zoom in and out on a target. Wash/wipe for the camera housing screen may be included.

PIP (PICTURE IN PICTURE)

Superimposes a reduced size picture from one camera over the full screen picture of another.

PSU (POWER SUPPLY UNIT)

Power supply units are normally used to provide low voltage ac or dc stepped down from 230 volts 50 Hz ac supplies. Typically 12-24 volts.

QUAD SPLITTER

A product that can display the views from 4 cameras simultaneously on one monitor. It is also possible to select any individual camera for full screen display on real time monitoring. As its name suggests the quad allows four cameras to be displayed simultaneously unlike the switcher which only shows one camera image on the monitor at any given time. The screen display is formed into four quadrants.

REFLECTED LIGHT

Scene illumination multiplied by reflectance. This is the amount of light returned to the camera lens and determines the quality of the picture.

REMOTE SWITCHERS

A video switcher to which the cables are connected from the cameras. This unit may be remotely connected to a desktop controller by a single cable for each monitor.

RESOLUTION	Resolution is the measurement of the ability of equipment and systems to resolve or produce 'sharp' pictures. It is specified as the number of black and white transitions per picture height measured horizontally across the screen.
RS232	Computer terminology. It is a widely used format for serial interfacing.
SCART	A universal connector/adaptor. Produced as a multi-pin it enables the employment of a number of functions related to input/output links.
SCENE ILLUMINATION	The density of light measured in lux falling upon the scene to be viewed.
SCREEN SPLITTER	A term used for displaying to camera on a single screen vertically, horizontally or inserted into another.
SENSITIVITY	Of a camera, usually specified in lux, should be the amount of light falling upon an imaging device to produce a full video signal.
SIMPLEX	A term used in multiplexing techniques. Has only one frame store which means the equipment can record or play only.
SVHS (SUPER VIDEO HOME SYSTEM)	Higher resolution recording than standard VHS.
SWITCHER	The switcher is a device that can display two or more cameras by switching between them for a pre-set period. It works to a sequence with the rate of switching (adjustable dwell time) between the cameras programmed by the system installer or user. Therefore it may be referred to as a sequential switcher. It provides a high quality resolution picture.
TELEMETRY	Control equipment using transmitter and receiver to remotely control functions at the camera.

- TERMINATION** In CCTV the standard impedance is 75 Ohms. Because 'Z' is the symbol for impedance, some manufacturers refer to the 75 Ohms termination on their equipment as Low Z.
- TIME LAPSE (VCR)** A type of video recorder that can be set to record continuously in time steps over long periods (from 24 to 960 hours typically). This is achieved by the tape mechanism moving in steps and recording either one field or one frame at a time. The domestic VCR is not suitable for CCTV recording purposes. However the time lapse device used for the recording of CCTV pictures is similar but is capable of operating continuously in a slow mode. By using this technique it can record a longer period of time on a standard E-180 VHS by taking a lesser number of pictures.
- TWISTED PAIR** A balanced cable transmission system that consists of two conductors.
- UNBALANCED SIGNAL** A term used for coaxial cable transmission.
- VARI-FOCAL** A type of lens which enables the focal length to be manually adjusted to produce different picture views.
- VHS (VIDEO HOME SYSTEM)**
Common name given to the 1/2" cassette tape used in video recorders. Lower resolution to SVHS.
- ZOOM LENS** A lens with a long focal length giving a high magnification but narrow angle (field) of view. Sometimes referred to as a telephoto lens.



CBC (EUROPE) Ltd.

7/8 Garrick Industrial Estate, Irving Way, London NW9 6AQ UK
Sales: +44 (0)20 8732 3334/3324/3310 **Fax:** +44 (0)20 8202 3387
Sales: info@cbcuk.com **Web:** www.cbceurope.com

Your local supplier is: